

# AGILA

1470PAO050P40

EAN 4031582335347

Swivel castor, housing made of pressed steel, bright zinc plated, blue passivated, double ball bearing swivel head, plate fitting. Wheel centre made of Polypropylene, Tread: Polyurethane, plain bearing



BETTER MOBILITY. BETTER LIFE.



Picture may differ from original product

## Technical Data

Wheel diameter	50 mm
Wheel width	19 mm
Castor width	44 mm
Size of Plate	60 x 60 mm
Plate hole centres	48/38 x 48/38 mm
Plate hole	6,3 mm
Dome-Ø	41 mm
Offset	25 mm
Swivel Interference	100 mm
Overall height	70 mm
Temperature	- 20 / + 60 °C
Standard	EN 12530
Weight	0.18 kg
Swivel Radius	50 mm
Hardness of tread	Shore D 40
Load capacity	40 kg
Load capacity (static)	80 kg

## Structure & Mounting

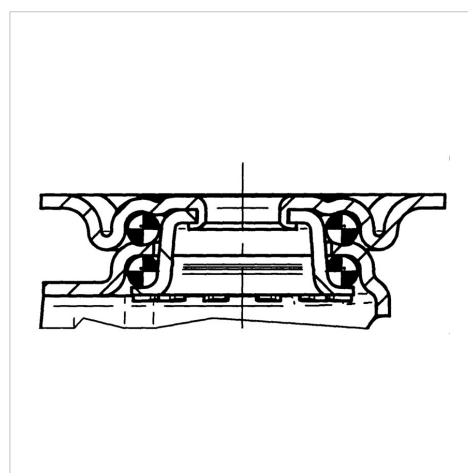

## Advantages at a glance

Roll performance	● ● ● ○ ○
Movement noise	● ● ● ○ ○
Attrition	● ● ● ● ○
Corrosion resistance	● ● ● ○ ○

# AGILA

1470PAO050P40

EAN 4031582335347



BETTER MOBILITY. BETTER LIFE.

## Structure & Mounting

