

# AGILA

1470PAO100P30-11-TUS

EAN 4031582387797

Swivel castor, housing made of pressed steel, bright zinc plated, blue passivated, double ball bearing swivel head, bolt hole. Wheel centre made of Polypropylene, Tread: Polyurethane, plain bearing



BETTER MOBILITY. BETTER LIFE.



Picture may differ from original product

## Technical Data

Wheel diameter	100 mm
Wheel width	25 mm
Centre hole	11 mm
Offset	28 mm
Swivel Interference	156 mm
Overall height	125 mm
Temperature	- 20 / + 60 °C
Standard	EN 12530
Swivel Radius	78 mm
Hardness of tread	Shore D 40
Load capacity	75 kg
Load capacity (static)	150 kg

## Structure & Mounting

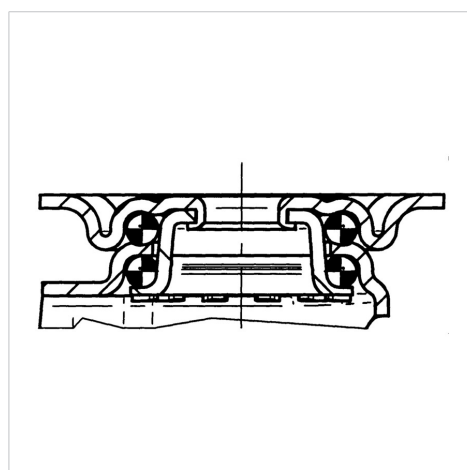

## Advantages at a glance

Roll performance	● ● ● ○ ○
Movement noise	● ● ● ○ ○
Attrition	● ● ● ● ○
Corrosion resistance	● ● ● ○ ○