

AGILA

1470PAO100P50

EAN 4031582331523

Swivel castor, housing made of pressed steel, bright zinc plated, blue passivated, double ball bearing swivel head, plate fitting. Wheel centre made of Polypropylene, Tread: Polyurethane, plain bearing



BETTER MOBILITY. BETTER LIFE.



Picture may differ from original product

Technical Data

Wheel diameter	100 mm
Wheel width	25 mm
Castor width	44 mm
Size of Plate	77 x 67 mm
Plate hole centres	61,5/56 x 51,5/46,5 mm
Plate hole	8,5 mm
Dome-Ø	41 mm
Offset	28 mm
Swivel Interference	156 mm
Overall height	125 mm
Temperature	- 20 / + 60 °C
Standard	EN 12530
Weight	0.309 kg
Swivel Radius	78 mm
Hardness of tread	Shore D 40
Load capacity	70 kg
Load capacity (static)	140 kg

Structure & Mounting

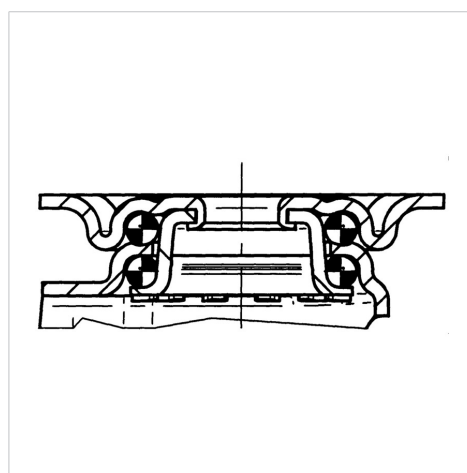

Advantages at a glance

Roll performance	● ● ● ○ ○
Movement noise	● ● ● ○ ○
Attrition	● ● ● ● ○
Corrosion resistance	● ● ● ○ ○