

AGILA

1470POI050P40

EAN 4031582338546

Swivel castor, housing made of pressed steel, bright zinc plated, blue passivated, double ball bearing swivel head, plate fitting. Wheel centre made of Polypropylene, plain bearing



BETTER MOBILITY. BETTER LIFE.



Picture may differ from original product

Technical Data

Wheel diameter	50 mm
Wheel width	18 mm
Castor width	44 mm
Size of Plate	60 x 60 mm
Plate hole centres	48/38 x 48/38 mm
Plate hole	6,3 mm
Dome-Ø	41 mm
Offset	25 mm
Swivel Interference	100 mm
Overall height	70 mm
Temperature	- 20 / + 60 °C
Standard	EN 12530
Weight	0.192 kg
Swivel Radius	50 mm
Hardness of tread	Shore D 65
Load capacity	40 kg
Load capacity (static)	80 kg

Structure & Mounting

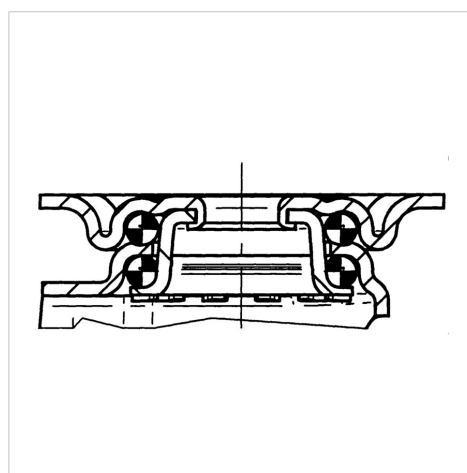

Advantages at a glance

Roll performance	● ● ● ○ ○
Movement noise	● ● ● ○ ○
Attrition	● ● ● ● ●
Corrosion resistance	● ● ● ○ ○

AGILA

1470POI050P40

EAN 4031582338546



BETTER MOBILITY. BETTER LIFE.

Structure & Mounting

