

AGILA

1470POO075P30-11

EAN 4031582338515

Swivel caster, housing made of pressed steel, bright zinc plated, blue passivated, double ball bearing swivel head, bolt hole. Wheel center made of Polypropylene, plain bearing



BETTER MOBILITY. BETTER LIFE.



Picture may differ from original product

Technical Data

Wheel diameter	75 mm
Wheel width	25 mm
Caster width	44 mm
Center hole	11 mm
Dome-Ø	41 mm
Offset	25 mm
Swivel Interference	125 mm
Overall height	100 mm
Temperature	- 20 / + 60 °C
Standard	EN 12530
Weight	0.213 kg
Swivel Radius	62.5 mm
Hardness of tread	Shore D 65
Load capacity (dynamic)	40 kg
Load capacity (static)	80 kg

Structure & Mounting

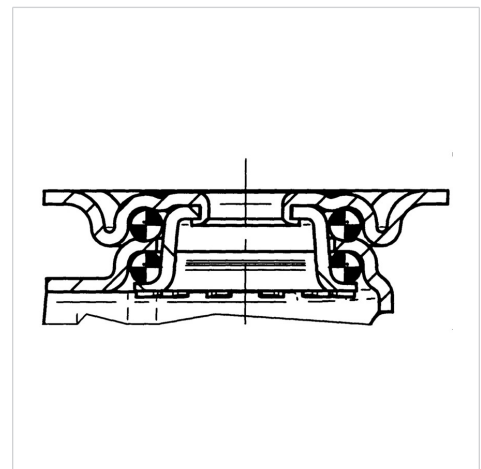

Advantages at a glance

Roll performance	● ● ● ○ ○
Movement noise	● ● ● ○ ○
Attrition	● ● ● ● ●
Corrosion resistance	● ● ● ○ ○