

# AGILA

1475PAO050P30-11

EAN 4031582338485

Swivel castor with wheel brake, housing made of pressed steel, bright zinc plated, blue passivated, double ball bearing swivel head, bolt hole.

Wheel centre made of Polypropylene, Tread: Polyurethane, plain bearing



BETTER MOBILITY. BETTER LIFE.



Picture may differ from original product

## Technical Data

Wheel diameter	50 mm
Wheel width	19 mm
Castor width	44 mm
Centre hole	11 mm
Dome-Ø	41 mm
Offset	25 mm
Swivel Interference	128 mm
Overall height	70 mm
Temperature	- 20 / + 60 °C
Standard	EN 12530
Weight	0.18 kg
Swivel Radius	64 mm
Hardness of tread	Shore D 40
Load capacity	40 kg
Load capacity (static)	80 kg

## Structure & Mounting

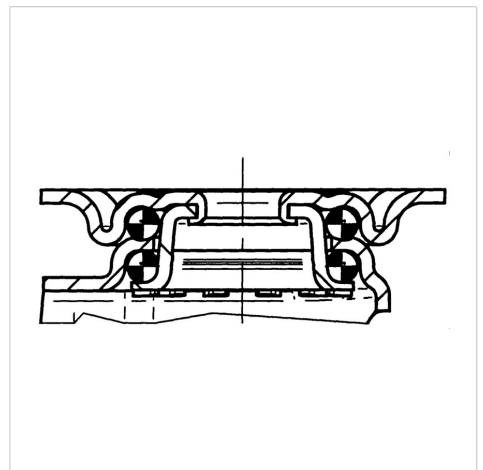

## Advantages at a glance

Roll performance	● ● ● ○ ○
Movement noise	● ● ● ○ ○
Attrition	● ● ● ● ○
Corrosion resistance	● ● ● ○ ○