

AGILA

1475PAO050P40

EAN 4031582331455

Swivel caster with wheel brake, housing made of pressed steel, bright zinc plated, blue passivated, double ball bearing swivel head, plate fitting.
Wheel center made of Polypropylene, Tread: Polyurethane, plain bearing



BETTER MOBILITY. BETTER LIFE.



Picture may differ from original product

Technical Data

Wheel diameter	50 mm
Wheel width	19 mm
Caster width	44 mm
Plate size	60 x 60 mm
Plate hole centers	48/38 x 48/38 mm
Plate hole	6,3 mm
Dome-Ø	41 mm
Offset	25 mm
Swivel Interference	128 mm
Overall height	70 mm
Temperature	- 20 / + 60 °C
Standard	EN 12530
Weight	0.21 kg
Swivel Radius	64 mm
Hardness of tread	Shore D 40
Load capacity (dynamic)	40 kg
Load capacity (static)	80 kg

Structure & Mounting

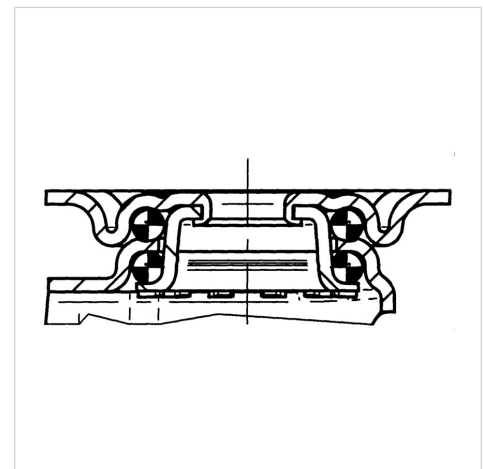

Advantages at a glance

Roll performance	● ● ● ○ ○
Movement noise	● ● ● ○ ○
Attrition	● ● ● ● ○
Corrosion resistance	● ● ● ○ ○

AGILA

1475PAO050P40

EAN 4031582331455



BETTER MOBILITY. BETTER LIFE.

Structure & Mounting

