

# AGILA

1475POI050P40

EAN 4031582338560

Swivel castor with wheel brake, housing made of pressed steel, bright zinc plated, blue passivated, double ball bearing swivel head, plate fitting. Wheel centre made of Polypropylene, plain bearing



BETTER MOBILITY. BETTER LIFE.



Picture may differ from original product

## Technical Data

Wheel diameter	50 mm
Wheel width	18 mm
Size of Plate	60 x 60 mm
Plate hole centres	48/38 x 48/38 mm
Plate hole	6,3 mm
Offset	25 mm
Swivel Interference	128 mm
Overall height	70 mm
Temperature	- 20 / + 60 °C
Standard	EN 12530
Weight	0.1 kg
Swivel Radius	64 mm
Hardness of tread	Shore D 65
Load capacity	40 kg
Load capacity (static)	80 kg

## Structure & Mounting

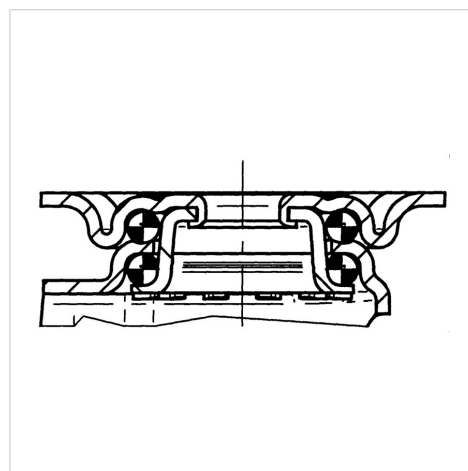

## Advantages at a glance

Roll performance	● ● ● ○ ○
Movement noise	● ● ● ○ ○
Attrition	● ● ● ● ●
Corrosion resistance	● ● ● ○ ○

# AGILA

1475POI050P40

EAN 4031582338560



BETTER MOBILITY. BETTER LIFE.

## Structure & Mounting

