

AGILA

1477PAO075P40

EAN 4031582331493

Swivel castor with total lock, tail end of castor, housing made of pressed steel, bright zinc plated, blue passivated, double ball bearing swivel head, plate fitting. Wheel centre made of Polypropylene, Tread: Polyurethane, plain bearing



BETTER MOBILITY. BETTER LIFE.



Picture may differ from original product

Technical Data

Wheel diameter	75 mm
Wheel width	25 mm
Castor width	44 mm
Size of Plate	60 x 60 mm
Plate hole centres	48/38 x 48/38 mm
Plate hole	6,3 mm
Dome-Ø	41 mm
Offset	25 mm
Swivel Interference	156 mm
Overall height	100 mm
Temperature	- 20 / + 60 °C
Standard	EN 12530
Weight	0.298 kg
Swivel Radius	78 mm
Hardness of tread	Shore D 40
Load capacity	60 kg
Load capacity (static)	120 kg

Structure & Mounting

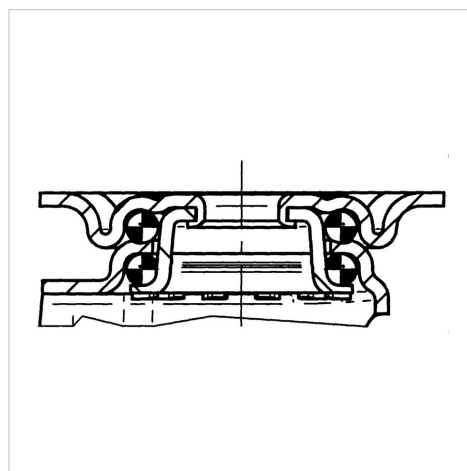

Advantages at a glance

Roll performance	● ● ● ○ ○
Movement noise	● ● ● ○ ○
Attrition	● ● ● ● ○
Corrosion resistance	● ● ● ○ ○

AGILA

1477PAO075P40

EAN 4031582331493



BETTER MOBILITY. BETTER LIFE.

Structure & Mounting

