

AGILA

1477POO075P30-11

EAN 4031582338539

Swivel castor with total lock, tail end of castor, housing made of pressed steel, bright zinc plated, blue passivated, double ball bearing swivel head, bolt hole. Wheel centre made of Polypropylene, plain bearing



BETTER MOBILITY. BETTER LIFE.



Picture may differ from original product

Technical Data

Wheel diameter	75 mm
Wheel width	25 mm
Castor width	44 mm
Centre hole	11 mm
Dome-Ø	41 mm
Offset	25 mm
Swivel Interference	156 mm
Overall height	100 mm
Temperature	- 20 / + 60 °C
Standard	EN 12530
Weight	0.265 kg
Swivel Radius	78 mm
Hardness of tread	Shore D 65
Load capacity	40 kg
Load capacity (static)	80 kg

Structure & Mounting

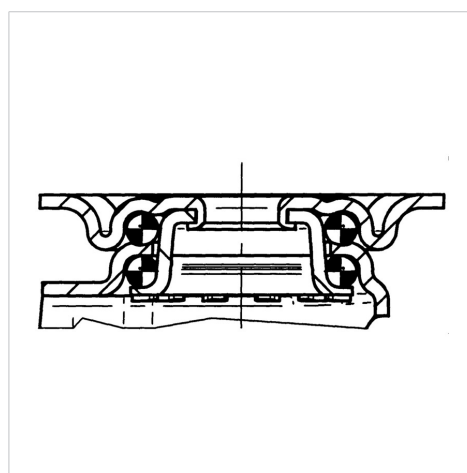

Advantages at a glance

Roll performance	● ● ● ○ ○
Movement noise	● ● ● ○ ○
Attrition	● ● ● ● ●
Corrosion resistance	● ● ● ○ ○