

INTEGRAL

2040UAX200R05-32

EAN 4031582300154

Swivel caster, Frame made of pressed steel, precision ball bearing in swivel head and wheel, housing cover made of synthetic plastic, solid plug fitting. Wheel center made of Polyamide, Tread: Polyurethane, with threadguards, precision ball bearing, sealed



BETTER MOBILITY. BETTER LIFE.



Picture may differ from original product

Technical Data

Wheel diameter	200 mm
Wheel width	35 mm
Caster width	70 mm
Bolt-Ø	32 mm
Bolt length	45 mm
Dome-Ø	70 mm
Offset	60 mm
Swivel Interference	320 mm
Overall height	229 mm
Temperature	- 25 / - 25 °C
Standard	EN 12531
Weight	1.67 kg
Swivel Radius	160 mm
Hardness of tread	Shore D 59
Load capacity (dynamic)	150 kg
Load capacity (static)	450 kg

Advantages at a glance

Roll performance	● ● ● ○ ○
Movement noise	● ● ● ○ ○
Attrition	● ● ● ○ ○
Corrosion resistance	● ● ● ○ ○

Dimensions

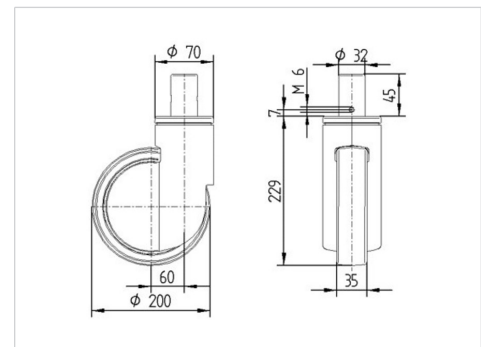

Structure & Mounting

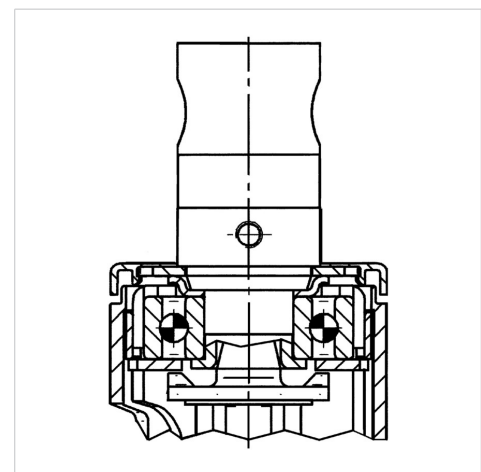

INTEGRAL

2040UAX200R05-32

EAN 4031582300154



BETTER MOBILITY. BETTER LIFE.

Structure & Mounting



product
design award
winner



reddot design award
winner