

# INTEGRAL

2044UAP150R36-32S30 4xM6

EAN 4031582300192

Swivel castor with central, total lock and central directional lock, frame made of pressed steel, precision ball bearing in swivel head and wheel, housing cover made of synthetic plastics, stem with cam hole for profile bars, short version. Wheel centre made of Polyamide, Tread: Polyurethane, precision ball bearing  
Hint: TÜV Süd certified product.



BETTER MOBILITY. BETTER LIFE.



Picture may differ from original product

## Technical Data

Wheel diameter	150 mm
Wheel width	32 mm
Castor width	62 mm
Bolt-Ø	32 mm
Bolt length	51 mm
Dome-Ø	62 mm
Offset	40 mm
Swivel Interference	230 mm
Overall height	183 mm
Temperature	- 25 / - 25 °C
Standard	EN 12531
Weight	1.095 kg
Swivel Radius	115 mm
Hardness of tread	Shore D 42
Load capacity	150 kg
Load capacity (static)	450 kg

## Advantages at a glance

Roll performance	● ● ● ○ ○
Movement noise	● ● ● ○ ○
Attrition	● ● ● ● ○
Corrosion resistance	● ● ● ○ ○

## Dimensions

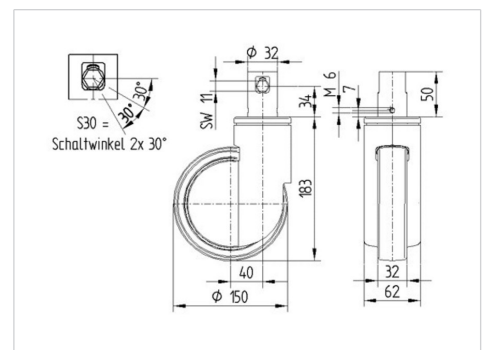

## Structure & Mounting

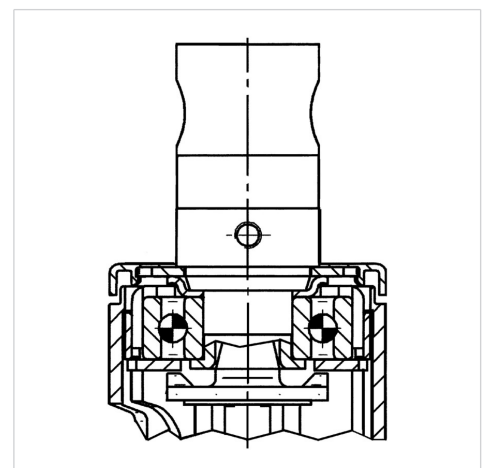

# INTEGRAL

2044UAP150R36-32S30 4xM6

EAN 4031582300192



BETTER MOBILITY. BETTER LIFE.

## Structure & Mounting

---

