

STORA

2370DIK100P30-11

EAN 4031582300307

Swivel castor, housing made of pressed steel, bright zinc plated, blue passivated, double ball bearing swivel head, wheel axle with nut, bolt hole. Wheel centre made of pressed steel, Tread: solid rubber, grey non-marking, with threadguards, cone ball bearing



BETTER MOBILITY. BETTER LIFE.



Picture may differ from original product

Technical Data

Wheel diameter	100 mm
Wheel width	32 mm
Centre hole	11 mm
Offset	35 mm
Swivel Interference	170 mm
Overall height	129 mm
Temperature	- 20 / + 85 °C
Standard	EN 12530
Weight	0.795 kg
Swivel Radius	85 mm
Hardness of tread	Shore A 80
Load capacity	80 kg
Load capacity (static)	160 kg

Dimensions

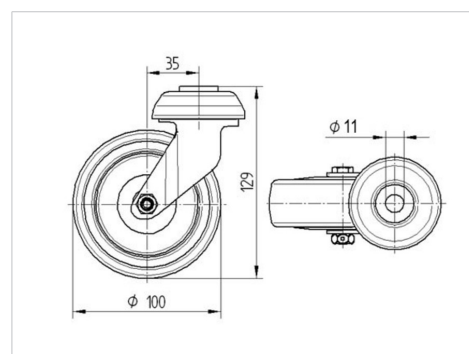

Advantages at a glance

Roll performance	● ● ● ○ ○
Movement noise	● ● ● ○ ○
Attrition	● ● ● ○ ○
Corrosion resistance	● ● ● ○ ○