

AGILA

2470DIK050B10-11x31

EAN 4031582300598

Swivel caster, housing made of pressed steel, bright zinc plated, blue passivated, double ball bearing swivel head, wheel axle with nut, stem with circlip. Wheel center made of pressed steel, Tread: solid rubber, grey non-marking, with threadguards, cone ball bearing



BETTER MOBILITY. BETTER LIFE.



Picture may differ from original product

Technical Data

Wheel diameter	50 mm
Wheel width	19 mm
Caster width	43 mm
Metal stem with circlip	11 x 31 mm
Dome-Ø	41 mm
Offset	24 mm
Swivel Interference	98 mm
Overall height	72 mm
Temperature	- 20 / + 85 °C
Standard	EN 12530
Weight	0.238 kg
Swivel Radius	49 mm
Hardness of tread	Shore A 80
Load capacity (dynamic)	40 kg
Load capacity (static)	80 kg

Dimensions

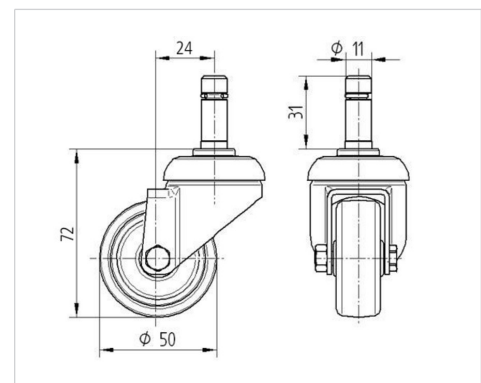

Structure & Mounting

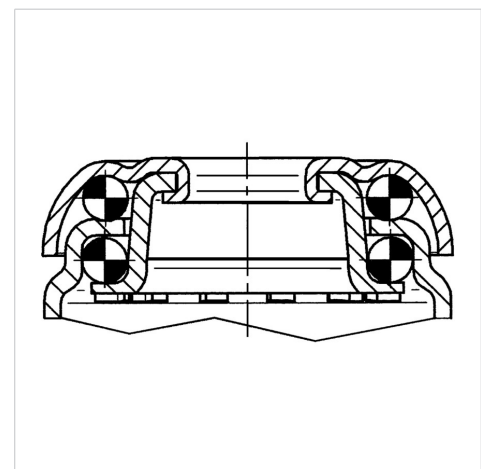

Advantages at a glance

Roll performance	● ● ● ○ ○
Movement noise	● ● ● ○ ○
Attrition	● ● ● ○ ○
Corrosion resistance	● ● ● ○ ○