

AGILA

2470DIK050P30-11

EAN 4031582010091

Swivel caster, housing made of pressed steel, bright zinc plated, blue passivated, double ball bearing swivel head, wheel axle with nut, bolt hole. Wheel center made of pressed steel, Tread: solid rubber, grey non-marking, with threadguards, cone ball bearing casters can be mounted with standard screws; various length screws can be used.



BETTER MOBILITY. BETTER LIFE.



Picture may differ from original product

Technical Data

Wheel diameter	50 mm
Wheel width	19 mm
Caster width	43 mm
Center hole	11 mm
Dome-Ø	41 mm
Offset	24 mm
Swivel Interference	98 mm
Overall height	69 mm
Temperature	- 20 / + 85 °C
Standard	EN 12530
Weight	0.206 kg
Swivel Radius	49 mm
Hardness of tread	Shore A 80
Load capacity (dynamic)	40 kg
Load capacity (static)	80 kg

Dimensions

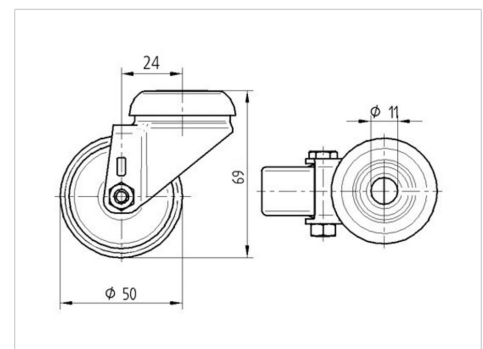

Structure & Mounting

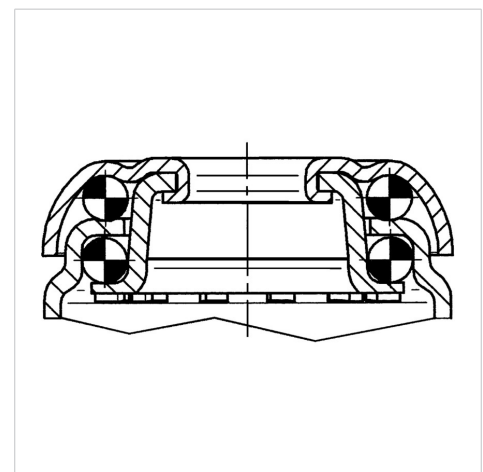

Advantages at a glance

Roll performance	● ● ● ○ ○
Movement noise	● ● ● ○ ○
Attrition	● ● ● ○ ○
Corrosion resistance	● ● ● ○ ○