

AGILA

2470DIK075P40

EAN 4031582010343

Swivel caster, housing made of pressed steel, bright zinc plated, blue passivated, double ball bearing swivel head, plate fitting. Wheel center made of pressed steel, Tread: solid rubber, grey non-marking, with threadguards, cone ball bearing



BETTER MOBILITY. BETTER LIFE.



Picture may differ from original product

Technical Data

Wheel diameter	75 mm
Wheel width	25 mm
Caster width	43 mm
Plate size	60 x 60 mm
Plate hole centers	48/38 x 48/38 mm
Plate hole	6,3 mm
Dome-Ø	43 mm
Offset	24 mm
Swivel Interference	123 mm
Overall height	100 mm
Temperature	- 20 / + 85 °C
Standard	EN 12530
Weight	0.397 kg
Swivel Radius	61.5 mm
Hardness of tread	Shore A 80
Load capacity (dynamic)	55 kg
Load capacity (static)	110 kg

Dimensions

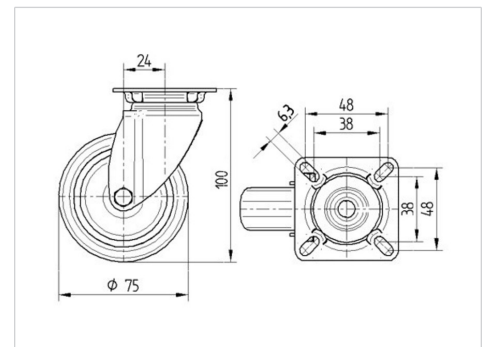

Structure & Mounting

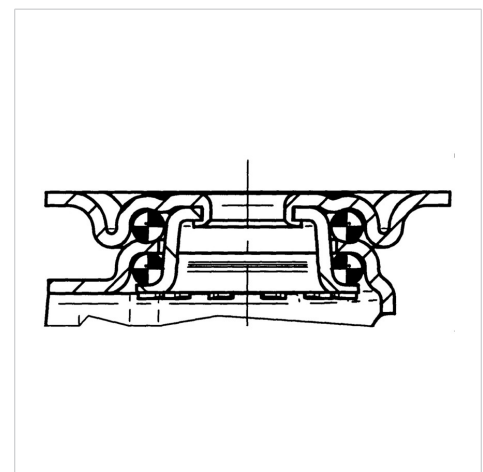

Advantages at a glance

Roll performance	● ● ● ○ ○
Movement noise	● ● ● ○ ○
Attrition	● ● ● ○ ○
Corrosion resistance	● ● ● ○ ○

AGILA

2470DIK075P40

EAN 4031582010343



BETTER MOBILITY. BETTER LIFE.

Structure & Mounting

