

AGILA

2470DIK075R47-27-30

EAN 4031582328189

Swivel castor, housing made of pressed steel, bright zinc plated, blue passivated, double ball bearing swivel head, expanding fitting (square). Wheel centre made of pressed steel, Tread: solid rubber, grey non-marking, with threadguards, cone ball bearing. Please indicate required tube innerdiameter when ordering.



BETTER MOBILITY. BETTER LIFE.



Picture may differ from original product

Technical Data

| | |
|------------------------|----------------|
| Wheel diameter | 75 mm |
| Wheel width | 25 mm |
| Expanding fitting-Ø | 27 - 30 mm |
| Offset | 24 mm |
| Swivel Interference | 123 mm |
| Overall height | 103 mm |
| Temperature | - 10 / + 40 °C |
| Standard | EN 12530 |
| Swivel Radius | 61.5 mm |
| Hardness of tread | Shore A 80 |
| Load capacity | 55 kg |
| Load capacity (static) | 110 kg |

Advantages at a glance

| | |
|----------------------|-----------|
| Roll performance | ● ● ● ○ ○ |
| Movement noise | ● ● ● ○ ○ |
| Attrition | ● ● ● ○ ○ |
| Corrosion resistance | ● ● ● ○ ○ |

Dimensions

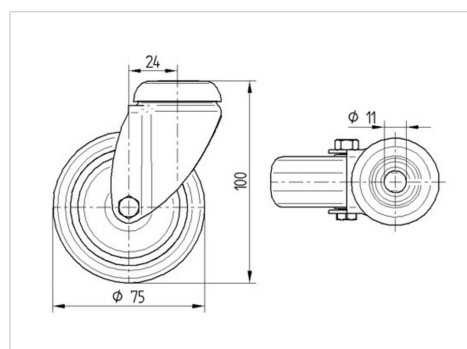

Structure & Mounting

