

# AGILA

2470DIK100R47-21,5-24

EAN 4031582328264

Swivel caster, housing made of pressed steel, bright zinc plated, blue passivated, double ball bearing swivel head, wheel axle with nut, expandable fitting (square). Wheel center made of pressed steel, Tread: solid rubber, grey non-marking, with threadguards, cone ball bearing. Please indicate required tube diameter when ordering.



BETTER MOBILITY. BETTER LIFE.



Picture may differ from original product

## Technical Data

Wheel diameter	100 mm
Wheel width	32 mm
Expandable fitting- $\emptyset$	21,5 - 24 mm
Offset	38 mm
Swivel Interference	176 mm
Overall height	138 mm
Temperature	- 10 / + 40 °C
Standard	EN 12530
Weight	0.954 kg
Swivel Radius	88 mm
Hardness of tread	Shore A 80
Load capacity (dynamic)	80 kg
Load capacity (static)	160 kg

## Advantages at a glance

Roll performance	● ● ● ○ ○
Movement noise	● ● ● ○ ○
Attrition	● ● ● ○ ○
Corrosion resistance	● ● ● ○ ○

## Dimensions

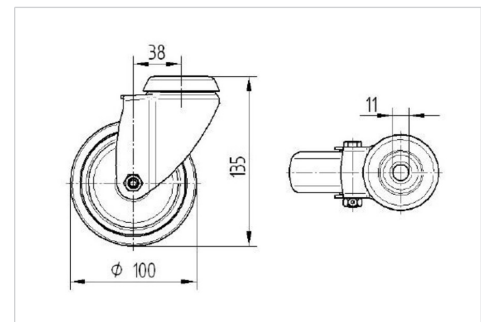

## Structure & Mounting

