

# AGILA

2470DIK125P30-11

EAN 4031582010350

Swivel caster, housing made of pressed steel, bright zinc plated, blue passivated, double ball bearing swivel head, wheel axle with nut, bolt hole. Wheel center made of pressed steel, Tread: solid rubber, grey non-marking, with threadguards, cone ball bearing casters can be mounted with standard screws; various length screws can be used.



BETTER MOBILITY. BETTER LIFE.



Picture may differ from original product

## Technical Data

Wheel diameter	125 mm
Wheel width	32 mm
Caster width	60 mm
Center hole	11 mm
Dome-Ø	60 mm
Offset	41 mm
Swivel Interference	207 mm
Overall height	160 mm
Temperature	- 20 / + 80 °C
Standard	EN 12530
Weight	1.038 kg
Swivel Radius	103.5 mm
Hardness of tread	Shore A 80
Load capacity (dynamic)	100 kg
Load capacity (static)	200 kg

## Dimensions

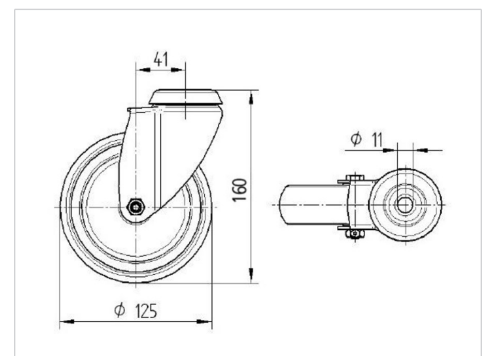

## Structure & Mounting

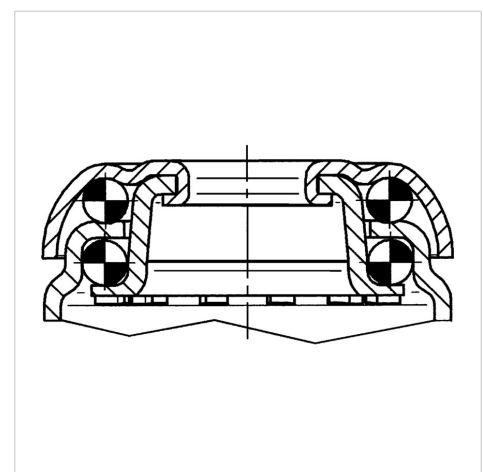

## Advantages at a glance

Roll performance	● ● ● ○ ○
Movement noise	● ● ● ○ ○
Attrition	● ● ● ○ ○
Corrosion resistance	● ● ● ○ ○