

AGILA

2470DIK125R47-27-30

EAN 4031582328387

Swivel castor, housing made of pressed steel, bright zinc plated, blue passivated, double ball bearing swivel head, wheel axle with nut, expanding fitting (square). Wheel centre made of pressed steel, Tread: solid rubber, grey non-marking, with threadguards, cone ball bearing. Please indicate required tube innerdiameter when ordering.



BETTER MOBILITY. BETTER LIFE.



Picture may differ from original product

Technical Data

Wheel diameter	125 mm
Wheel width	32 mm
Castor width	60 mm
Expanding fitting-Ø	27 - 30 mm
Dome-Ø	60 mm
Offset	41 mm
Swivel Interference	207 mm
Overall height	162.5 mm
Temperature	- 10 / + 40 °C
Standard	EN 12530
Weight	1.178 kg
Swivel Radius	103.5 mm
Hardness of tread	Shore A 80
Load capacity	100 kg
Load capacity (static)	200 kg

Advantages at a glance

Roll performance	● ● ● ○ ○
Movement noise	● ● ● ○ ○
Attrition	● ● ● ○ ○
Corrosion resistance	● ● ● ○ ○

Dimensions

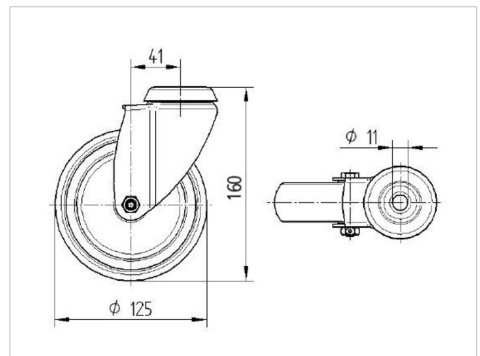

Structure & Mounting

