

AGILA

2470PIP150P30-11

EAN 4031582361384

Swivel caster, housing made of pressed steel, bright zinc plated, blue passivated, double ball bearing swivel head, wheel axle with nut, bolt hole. Wheel center made of Polypropylene, Tread: solid rubber, grey non-marking, precision ball bearing casters can be mounted with standard screws; various length screws can be used.



BETTER MOBILITY. BETTER LIFE.



Picture may differ from original product

Technical Data

Wheel diameter	150 mm
Wheel width	32 mm
Center hole	11 mm
Offset	45 mm
Swivel Interference	240 mm
Overall height	185 mm
Temperature	- 20 / + 60 °C
Standard	EN 12530
Weight	0.833 kg
Swivel Radius	120 mm
Hardness of tread	Shore A 75
Load capacity (dynamic)	80 kg
Load capacity (static)	160 kg

Advantages at a glance

Roll performance	● ● ● ○ ○
Movement noise	● ● ● ○ ○
Attrition	● ● ● ○ ○
Corrosion resistance	● ● ● ○ ○

Dimensions

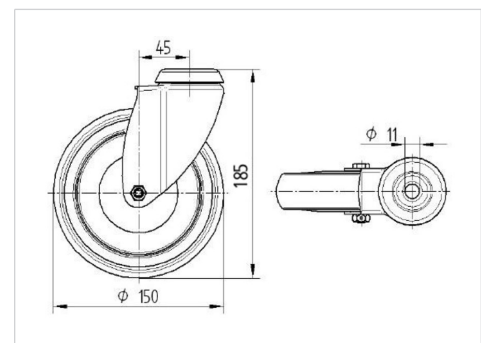

Structure & Mounting

