

# AGILA

2470PJO100P30-11

EAN 4031582010411

Swivel caster, housing made of pressed steel, bright zinc plated, blue passivated, double ball bearing swivel head, wheel axle with nut, bolt hole. Wheel center made of Polypropylene, Tread: TENTEprene (thermoplastic rubber), grey non-marking, plain bearing casters can be mounted with standard screws; various length screws can be used.



BETTER MOBILITY. BETTER LIFE.



Picture may differ from original product

## Technical Data

Wheel diameter	100 mm
Wheel width	32 mm
Caster width	60 mm
Center hole	11 mm
Dome-Ø	60 mm
Offset	38 mm
Swivel Interference	176 mm
Overall height	135 mm
Temperature	- 20 / + 60 °C
Standard	EN 12530
Weight	0.55 kg
Swivel Radius	88 mm
Hardness of tread	Shore A 87
Load capacity (dynamic)	80 kg
Load capacity (static)	160 kg

## Dimensions

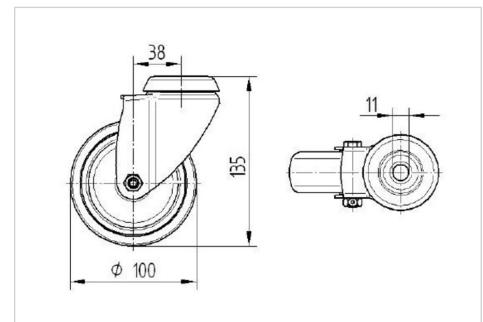

## Structure & Mounting

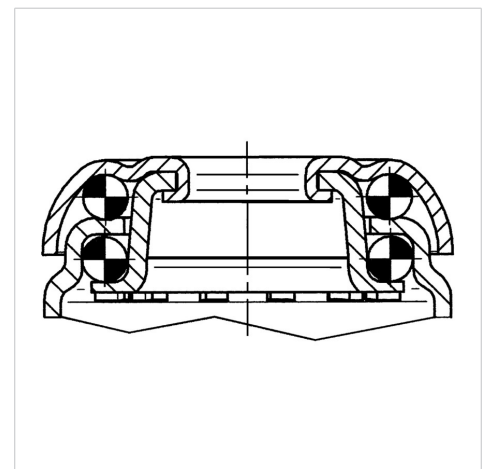

## Advantages at a glance

Roll performance	● ● ● ○ ○
Movement noise	● ● ● ○ ○
Attrition	● ● ● ○ ○
Corrosion resistance	● ● ● ○ ○