

# AGILA

2470UAK050P30-11

EAN 4031582301083

Swivel castor, housing made of pressed steel, bright zinc plated, blue passivated, double ball bearing swivel head, wheel axle with nut, bolt hole. Wheel centre made of Polyamide, Tread: Polyurethane, with threadguards, cone ball bearing. Castors can be mounted with standard screws; various length screws can be used.



BETTER MOBILITY. BETTER LIFE.



Picture may differ from original product

## Technical Data

Wheel diameter	50 mm
Wheel width	20 mm
Castor width	43 mm
Centre hole	11 mm
Dome-Ø	41 mm
Offset	24 mm
Swivel Interference	98 mm
Overall height	69 mm
Temperature	- 25 / - 25 °C
Standard	EN 12530
Weight	0.188 kg
Swivel Radius	49 mm
Hardness of tread	Shore D 42
Load capacity	50 kg
Load capacity (static)	100 kg

## Advantages at a glance

Roll performance	● ● ● ○ ○
Movement noise	● ● ● ○ ○
Attrition	● ● ● ● ○
Corrosion resistance	● ● ● ○ ○

## Dimensions

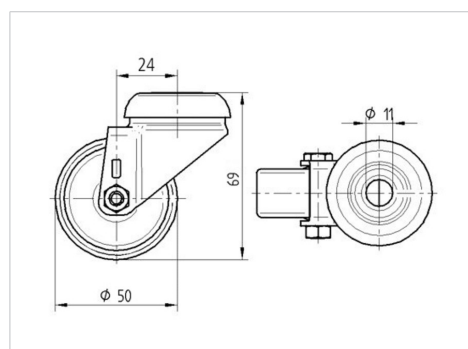

## Structure & Mounting

