

# AGILA

## 2470UAP125P50

EAN 4031582301168

Swivel castor, housing made of pressed steel, bright zinc plated, blue passivated, double ball bearing swivel head, wheel axle with nut, plate fitting. Wheel centre made of Polyamide, Tread: Polyurethane, precision ball bearing, with threadguards



BETTER MOBILITY. BETTER LIFE.



Picture may differ from original product

### Technical Data

Wheel diameter	125 mm
Wheel width	32 mm
Castor width	60 mm
Size of Plate	77 x 67 mm
Plate hole centres	61,5/56 x 51,5/46,5 mm
Plate hole	8,5 mm
Dome-Ø	60 mm
Offset	41 mm
Swivel Interference	207 mm
Overall height	160 mm
Temperature	- 25 / - 25 °C
Standard	EN 12530
Weight	0.85 kg
Swivel Radius	103.5 mm
Hardness of tread	Shore D 42
Load capacity	100 kg
Load capacity (static)	200 kg

### Advantages at a glance

Roll performance	● ● ● ○ ○
Movement noise	● ● ● ○ ○
Attrition	● ● ● ● ○
Corrosion resistance	● ● ● ○ ○

### Dimensions

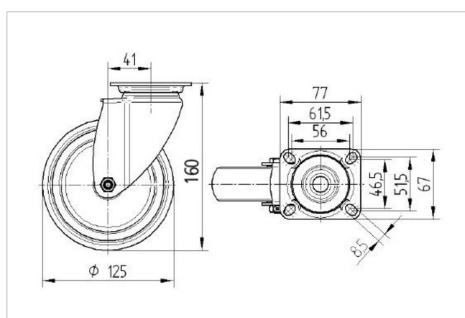

### Structure & Mounting

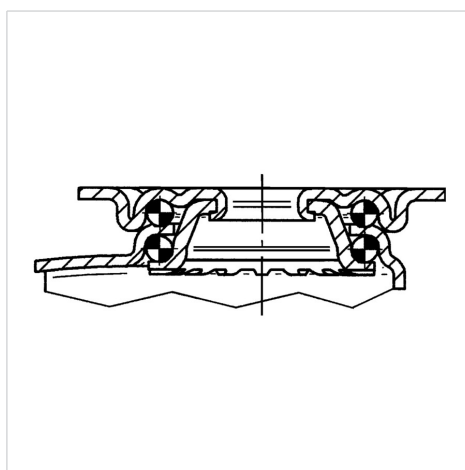

# AGILA

2470UAP125P50

EAN 4031582301168



BETTER MOBILITY. BETTER LIFE.

## Structure & Mounting

