

AGILA

2470UOK050P40

EAN 4031582301267

Swivel caster, housing made of pressed steel, bright zinc plated, blue passivated, double ball bearing swivel head, wheel axle with nut, plate fitting. Wheel center made of Polyamide, with threadguards, cone ball bearing



BETTER MOBILITY. BETTER LIFE.



Picture may differ from original product

Technical Data

Wheel diameter	50 mm
Wheel width	19 mm
Plate size	60 x 60 mm
Plate hole centers	48/38 x 48/38 mm
Plate hole	6,3 mm
Offset	24 mm
Swivel Interference	98 mm
Overall height	69 mm
Temperature	- 40 / + 80 °C
Standard	EN 12530
Weight	0.222 kg
Swivel Radius	49 mm
Hardness of tread	Shore D 75
Load capacity (dynamic)	50 kg
Load capacity (static)	100 kg

Dimensions

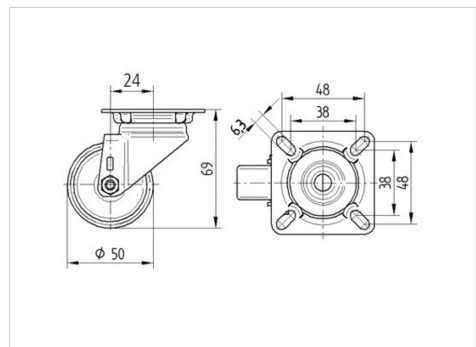

Structure & Mounting

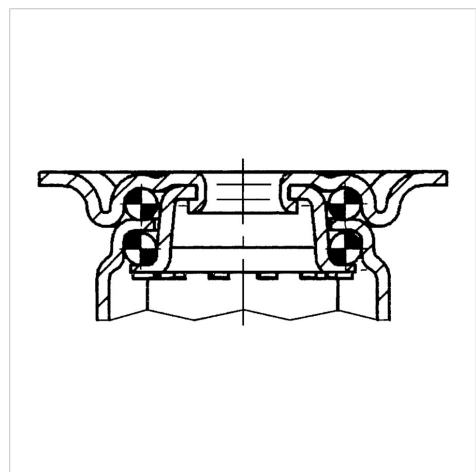

Advantages at a glance

Roll performance	● ● ● ● ○
Movement noise	● ● ● ○ ○
Attrition	● ● ● ● ●
Corrosion resistance	● ● ● ○ ○

AGILA

2470UOK050P40

EAN 4031582301267



BETTER MOBILITY. BETTER LIFE.

Structure & Mounting

