

## 2471PJP100P50

EAN 4031582301410

Swivel caster with directional lock, housing made of pressed steel, bright zinc plated, blue passivated, double ball bearing swivel head, wheel axle with nut, plate fitting. Wheel center made of Polypropylene, Tread: TENTEprene (thermoplastic rubber), grey non-marking, precision ball bearing, with threadguards



BETTER MOBILITY. BETTER LIFE.



Picture may differ from original product

### Technical Data

Wheel diameter	100 mm
Wheel width	32 mm
Caster width	60 mm
Plate size	77 x 67 mm
Plate hole centers	61,5/56 x 51,5/46,5 mm
Plate hole	8,5 mm
Dome-Ø	60 mm
Offset	43.5 mm
Swivel Interference	262 mm
Overall height	135 mm
Temperature	- 20 / + 60 °C
Standard	EN 12530
Weight	0.822 kg
Swivel Radius	131 mm
Hardness of tread	Shore A 87
Load capacity (dynamic)	100 kg
Load capacity (static)	200 kg

### Dimensions

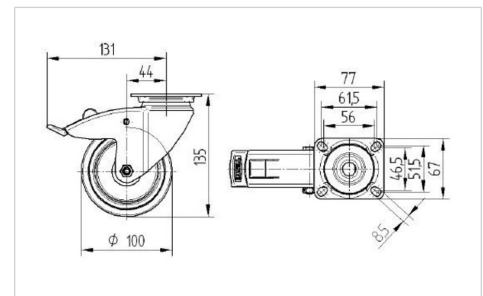

### Structure & Mounting

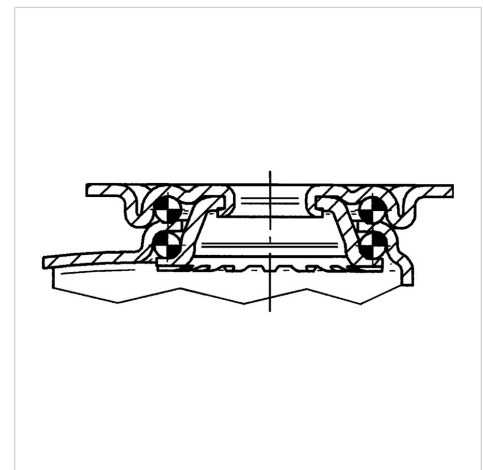

### Advantages at a glance

Roll performance	● ● ● ○ ○
Movement noise	● ● ● ○ ○
Attrition	● ● ● ○ ○
Corrosion resistance	● ● ● ○ ○



BETTER MOBILITY. BETTER LIFE.

## 2471PJP100P50

EAN 4031582301410

### Structure & Mounting

---

