

2471PJP125P50

EAN 4031582301434

Swivel castor with directional lock, housing made of pressed steel, bright zinc plated, blue passivated, double ball bearing swivel head, wheel axle with nut, plate fitting. Wheel centre made of Polypropylene, Tread: TENTEprene (thermoplastic rubber), grey non-marking, precision ball bearing, with threadguards



BETTER MOBILITY. BETTER LIFE.



Picture may differ from original product

Technical Data

Wheel diameter	125 mm
Wheel width	32 mm
Size of Plate	77 x 67 mm
Plate hole centres	61,5/56 x 51,5/46,5 mm
Plate hole	8,5 mm
Offset	41 mm
Swivel Interference	262 mm
Overall height	160 mm
Temperature	- 20 / + 60 °C
Standard	EN 12530
Weight	0.928 kg
Swivel Radius	131 mm
Hardness of tread	Shore A 87
Load capacity	100 kg
Load capacity (static)	200 kg

Advantages at a glance

Roll performance	● ● ● ○ ○
Movement noise	● ● ● ○ ○
Attrition	● ● ● ○ ○
Corrosion resistance	● ● ● ○ ○

Dimensions

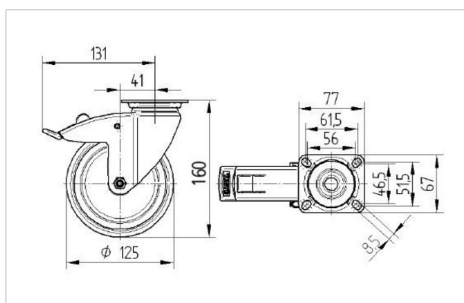

Structure & Mounting

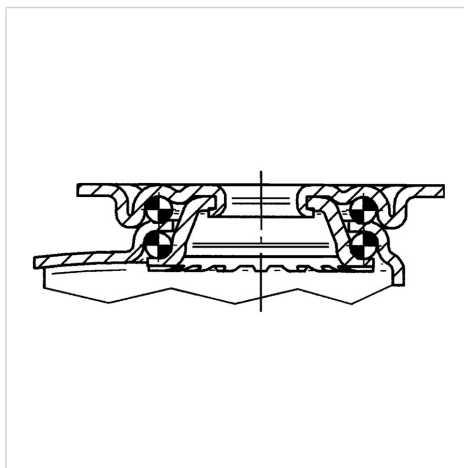



BETTER MOBILITY. BETTER LIFE.

2471PJP125P50

EAN 4031582301434

Structure & Mounting

