

2471PJP125R05-28

EAN 4031582301441

Swivel castor with directional lock, housing made of pressed steel, bright zinc plated, blue passivated, double ball bearing swivel head, wheel axle with nut, solid plug fitting. Wheel centre made of Polypropylene, Tread: TENTEprene (thermoplastic rubber), grey non-marking, precision ball bearing, with threadguards



BETTER MOBILITY. BETTER LIFE.



Picture may differ from original product

Technical Data

| | |
|------------------------|----------------|
| Wheel diameter | 125 mm |
| Wheel width | 32 mm |
| Castor width | 60 mm |
| Bolt-Ø | 28 mm |
| Bolt length | 45 mm |
| Dome-Ø | 60 mm |
| Offset | 41 mm |
| Swivel Interference | 262 mm |
| Overall height | 160 mm |
| Temperature | - 20 / + 60 °C |
| Standard | EN 12530 |
| Weight | 1.092 kg |
| Swivel Radius | 131 mm |
| Hardness of tread | Shore A 83 |
| Load capacity | 100 kg |
| Load capacity (static) | 200 kg |

Dimensions

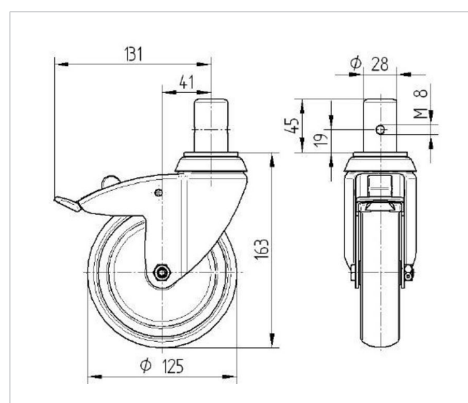

Structure & Mounting

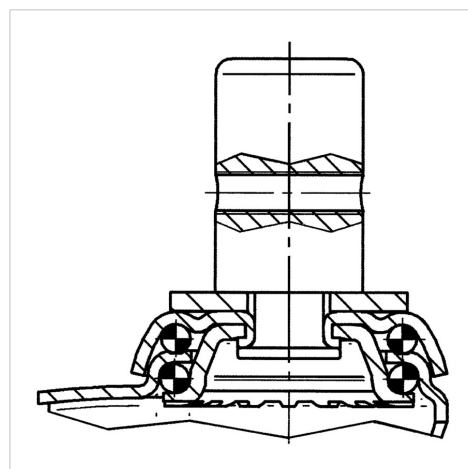

Advantages at a glance

| | |
|----------------------|-----------|
| Roll performance | ● ● ● ○ ○ |
| Movement noise | ● ● ● ○ ○ |
| Attrition | ● ● ● ○ ○ |
| Corrosion resistance | ● ● ● ○ ○ |