

# AGILA

2476DIK125R26-28S45

EAN 4031582301717

Swivel castor with central total lock, housing made of pressed steel, bright zinc plated, blue passivated, double ball bearing swivel head, wheel axle with nut, stem with cam hole for profile bars. Wheel centre made of pressed steel, Tread: solid rubber, grey non-marking, with threadguards, cone ball bearing



BETTER MOBILITY. BETTER LIFE.



Picture may differ from original product

## Technical Data

Wheel diameter	125 mm
Wheel width	32 mm
Castor width	60 mm
Bolt-Ø	28 mm
Bolt length	96 mm
Dome-Ø	60 mm
Offset	41 mm
Swivel Interference	207 mm
Overall height	163 mm
Temperature	- 20 / + 60 °C
Standard	EN 12530
Weight	1.275 kg
Swivel Radius	103.5 mm
Hardness of tread	Shore A 80
Load capacity	100 kg
Load capacity (static)	200 kg

## Dimensions

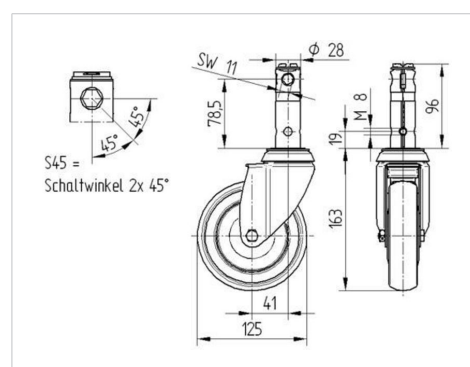

## Advantages at a glance

Roll performance	● ● ● ○ ○
Movement noise	● ● ● ○ ○
Attrition	● ● ● ○ ○
Corrosion resistance	● ● ● ○ ○