

AGILA

2477DIK075P30-11

EAN 4031582050288

Swivel castor with total lock, tail end of castor, housing made of pressed steel, bright zinc plated, blue passivated, double ball bearing swivel head, bolt hole. Wheel centre made of pressed steel, Tread: solid rubber, grey non-marking, with threadguards, cone ball bearing. Castors can be mounted with standard screws; various length screws can be used.



BETTER MOBILITY. BETTER LIFE.



Picture may differ from original product

Technical Data

Wheel diameter	75 mm
Wheel width	25 mm
Castor width	43 mm
Centre hole	11 mm
Dome-Ø	43 mm
Offset	24 mm
Swivel Interference	160 mm
Overall height	100 mm
Temperature	- 20 / + 85 °C
Standard	EN 12530
Weight	0.418 kg
Swivel Radius	80 mm
Hardness of tread	Shore A 80
Load capacity	55 kg
Load capacity (static)	110 kg

Dimensions

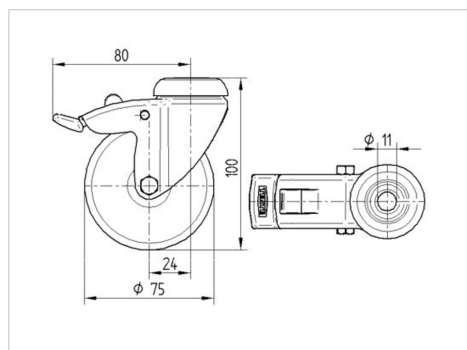

Structure & Mounting

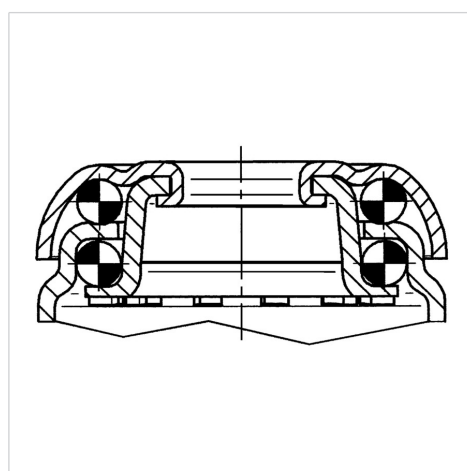

Advantages at a glance

Roll performance	● ● ● ○ ○
Movement noise	● ● ● ○ ○
Attrition	● ● ● ○ ○
Corrosion resistance	● ● ● ○ ○