

AGILA

2477DIK100R05-28

EAN 4031582301878

Swivel caster with total lock, trailing end of caster, housing made of pressed steel, bright zinc plated, blue passivated, double ball bearing swivel head, wheel axle with nut, solid plug fitting. Wheel center made of pressed steel, Tread: solid rubber, grey non-marking, with threadguards, cone ball bearing



BETTER MOBILITY. BETTER LIFE.



Picture may differ from original product

Technical Data

Wheel diameter	100 mm
Wheel width	32 mm
Caster width	60 mm
Bolt-Ø	28 mm
Bolt length	45 mm
Dome-Ø	60 mm
Offset	43.5 mm
Swivel Interference	262 mm
Overall height	138 mm
Temperature	- 20 / + 85 °C
Standard	EN 12530
Weight	1.28 kg
Swivel Radius	131 mm
Hardness of tread	Shore A 80
Load capacity (dynamic)	80 kg
Load capacity (static)	160 kg

Dimensions

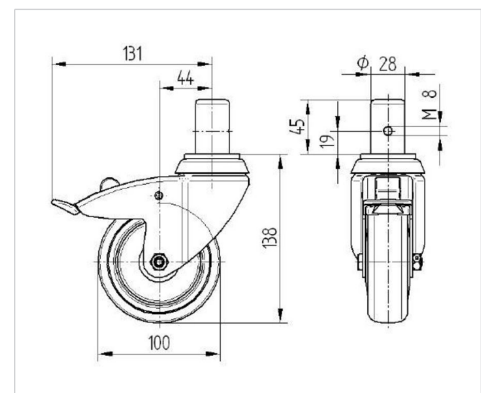

Structure & Mounting

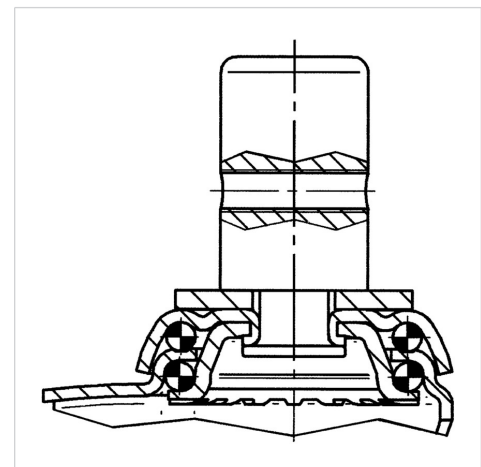

Advantages at a glance

Roll performance	● ● ● ○ ○
Movement noise	● ● ● ○ ○
Attrition	● ● ● ○ ○
Corrosion resistance	● ● ● ○ ○