

AGILA

2477DIK125P30-11

EAN 4031582050325

Swivel castor with total lock, tail end of castor, housing made of pressed steel, bright zinc plated, blue passivated, double ball bearing swivel head, wheel axle with nut, bolt hole. Wheel centre made of pressed steel, Tread: solid rubber, grey non-marking, with threadguards, cone ball bearing Castors can be mounted with standard screws; various length screws can be used.



BETTER MOBILITY. BETTER LIFE.



Picture may differ from original product

Technical Data

Wheel diameter	125 mm
Wheel width	32 mm
Castor width	60 mm
Centre hole	11 mm
Dome-Ø	60 mm
Offset	41 mm
Swivel Interference	262 mm
Overall height	160 mm
Temperature	- 20 / + 80 °C
Standard	EN 12530
Weight	1.213 kg
Swivel Radius	131 mm
Hardness of tread	Shore A 80
Load capacity	100 kg
Load capacity (static)	200 kg

Advantages at a glance

Roll performance	● ● ● ○ ○
Movement noise	● ● ● ○ ○
Attrition	● ● ● ○ ○
Corrosion resistance	● ● ● ○ ○

Dimensions

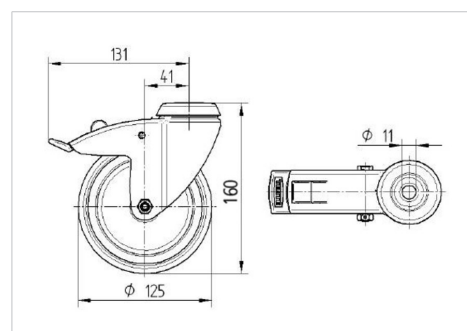

Structure & Mounting

