

AGILA

2477DIK125R05-28

EAN 4031582301915

Swivel castor with total lock, tail end of castor, housing made of pressed steel, bright zinc plated, blue passivated, double ball bearing swivel head, wheel axle with nut, solid plug fitting. Wheel centre made of pressed steel, Tread: solid rubber, grey non-marking, with threadguards, cone ball bearing



BETTER MOBILITY. BETTER LIFE.



Picture may differ from original product

Technical Data

Wheel diameter	125 mm
Wheel width	32 mm
Castor width	60 mm
Bolt-Ø	28 mm
Bolt length	45 mm
Dome-Ø	60 mm
Offset	41 mm
Swivel Interference	262 mm
Overall height	163 mm
Temperature	- 20 / + 80 °C
Standard	EN 12530
Weight	1.486 kg
Swivel Radius	131 mm
Hardness of tread	Shore A 80
Load capacity	100 kg
Load capacity (static)	200 kg

Advantages at a glance

Roll performance	● ● ● ○ ○
Movement noise	● ● ● ○ ○
Attrition	● ● ● ○ ○
Corrosion resistance	● ● ● ○ ○

Dimensions

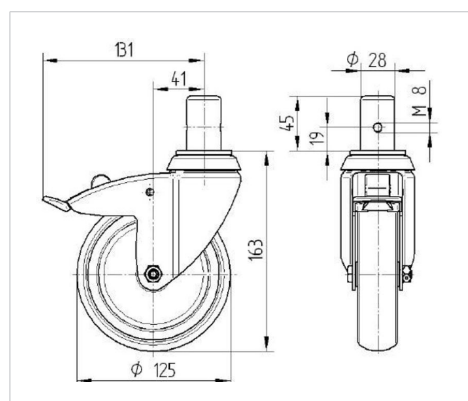

Structure & Mounting

