

# AGILA

2477DIK125R07-Ø31-35

EAN 4031582326093

Swivel castor with total lock, tail end of castor, housing made of pressed steel, bright zinc plated, blue passivated, double ball bearing swivel head, wheel axle with nut, Expanding fittings, round. Wheel centre made of pressed steel, Tread: solid rubber, grey non-marking, with threadguards, cone ball bearing Please indicate required tube innerdiameter when ordering.



BETTER MOBILITY. BETTER LIFE.



Picture may differ from original product

## Technical Data

Wheel diameter	125 mm
Wheel width	32 mm
Expanding fitting-Ø	31 - 35 mm
Offset	41 mm
Swivel Interference	262 mm
Overall height	163 mm
Temperature	- 10 / + 40 °C
Standard	EN 12530
Swivel Radius	131 mm
Hardness of tread	Shore A 80
Load capacity	100 kg
Load capacity (static)	200 kg

## Advantages at a glance

Roll performance	● ● ● ○ ○
Movement noise	● ● ● ○ ○
Attrition	● ● ● ○ ○
Corrosion resistance	● ● ● ○ ○

## Dimensions

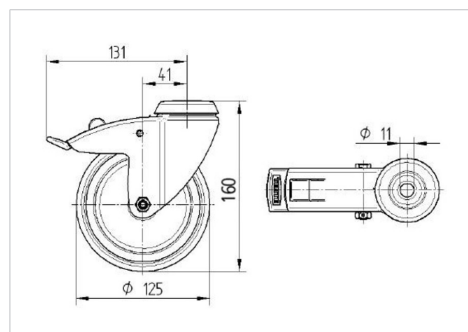

## Structure & Mounting

