

AGILA

2477PIP150P30-11

EAN 4031582362138

Swivel castor with total lock, tail end of castor, housing made of pressed steel, bright zinc plated, blue passivated, double ball bearing swivel head, wheel axle with nut, bolt hole. Wheel centre made of Polypropylene, Tread: solid rubber, grey non-marking, precision ball bearing. Castors can be mounted with standard screws; various length screws can be used.



BETTER MOBILITY. BETTER LIFE.



Picture may differ from original product

Technical Data

Wheel diameter	150 mm
Wheel width	32 mm
Centre hole	11 mm
Offset	36 mm
Swivel Interference	262 mm
Overall height	185 mm
Temperature	- 20 / + 60 °C
Standard	EN 12530
Weight	0.988 kg
Swivel Radius	131 mm
Hardness of tread	Shore A 75
Load capacity	80 kg
Load capacity (static)	160 kg

Advantages at a glance

Roll performance	● ● ● ○ ○
Movement noise	● ● ● ○ ○
Attrition	● ● ● ○ ○
Corrosion resistance	● ● ● ○ ○

Dimensions

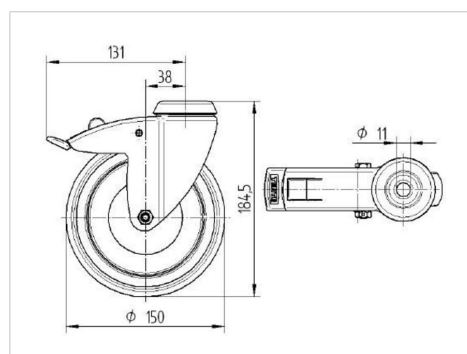

Structure & Mounting

