

# AGILA

2477PJO100R05-28

EAN 4031582301991

Swivel castor with total lock, tail end of castor, housing made of pressed steel, bright zinc plated, blue passivated, double ball bearing swivel head, wheel axle with nut, solid plug fitting. Wheel centre made of Polypropylene, Tread: TENTEprene (thermoplastic rubber), grey non-marking, plain bearing



BETTER MOBILITY. BETTER LIFE.



Picture may differ from original product

## Technical Data

Wheel diameter	100 mm
Wheel width	32 mm
Bolt-Ø	28 mm
Bolt length	45 mm
Offset	43.5 mm
Swivel Interference	262 mm
Overall height	138 mm
Temperature	- 20 / + 60 °C
Standard	EN 12530
Weight	0.982 kg
Swivel Radius	131 mm
Hardness of tread	Shore A 87
Load capacity	80 kg
Load capacity (static)	160 kg

## Advantages at a glance

Roll performance	● ● ● ○ ○
Movement noise	● ● ● ○ ○
Attrition	● ● ● ○ ○
Corrosion resistance	● ● ● ○ ○

## Dimensions

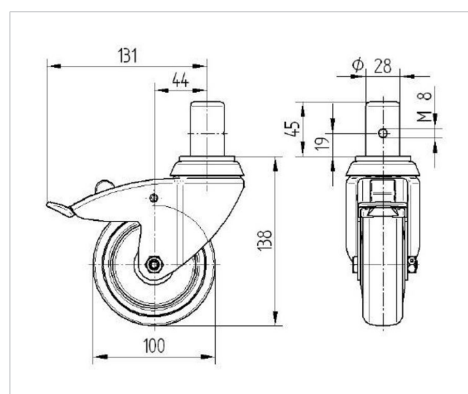

## Structure & Mounting

