

# AGILA

2477PJP100P30-11

EAN 4031582050448

Swivel caster with total lock, trailing end of caster, housing made of pressed steel, bright zinc plated, blue passivated, double ball bearing swivel head, wheel axle with nut, bolt hole. Wheel center made of Polypropylene, Tread: TENTEprene (thermoplastic rubber), grey non-marking, precision ball bearing, with threadguards casters can be mounted with standard screws; various length screws can be used.



BETTER MOBILITY. BETTER LIFE.



Picture may differ from original product

## Technical Data

Wheel diameter	100 mm
Wheel width	32 mm
Caster width	60 mm
Center hole	11 mm
Dome-Ø	60 mm
Offset	43.5 mm
Swivel Interference	262 mm
Overall height	135 mm
Temperature	- 20 / + 60 °C
Standard	EN 12530
Weight	0.766 kg
Swivel Radius	131 mm
Hardness of tread	Shore A 87
Load capacity (dynamic)	100 kg
Load capacity (static)	200 kg

## Advantages at a glance

Roll performance	● ● ● ○ ○
Movement noise	● ● ● ○ ○
Attrition	● ● ● ○ ○
Corrosion resistance	● ● ● ○ ○

## Dimensions

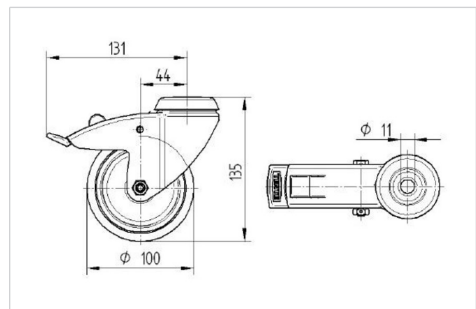

## Structure & Mounting

