

AGILA

2477PJP100P50

EAN 4031582050455

Swivel caster with total lock, trailing end of caster, housing made of pressed steel, bright zinc plated, blue passivated, double ball bearing swivel head, wheel axle with nut, plate fitting. Wheel center made of Polypropylene, Tread: TENTEprene (thermoplastic rubber), grey non-marking, precision ball bearing, with threadguards



BETTER MOBILITY. BETTER LIFE.



Picture may differ from original product

Technical Data

| | |
|-------------------------|------------------------|
| Wheel diameter | 100 mm |
| Wheel width | 32 mm |
| Caster width | 60 mm |
| Plate size | 77 x 67 mm |
| Plate hole centers | 61,5/56 x 51,5/46,5 mm |
| Plate hole | 8,5 mm |
| Dome-Ø | 60 mm |
| Offset | 43.5 mm |
| Swivel Interference | 262 mm |
| Overall height | 135 mm |
| Temperature | - 20 / + 60 °C |
| Standard | EN 12530 |
| Weight | 0.821 kg |
| Swivel Radius | 131 mm |
| Hardness of tread | Shore A 87 |
| Load capacity (dynamic) | 100 kg |
| Load capacity (static) | 200 kg |

Dimensions

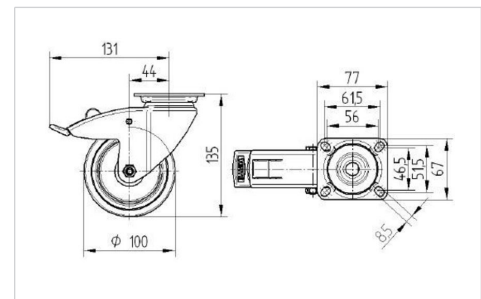

Structure & Mounting

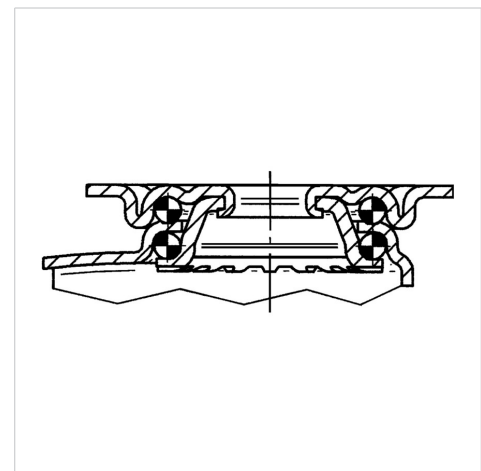

Advantages at a glance

| | |
|----------------------|-----------|
| Roll performance | ● ● ● ○ ○ |
| Movement noise | ● ● ● ○ ○ |
| Attrition | ● ● ● ○ ○ |
| Corrosion resistance | ● ● ● ○ ○ |

AGILA

2477PJP100P50

EAN 4031582050455



BETTER MOBILITY. BETTER LIFE.

Structure & Mounting

