

AGILA

2477UAP125P50

EAN 4031582302271

Swivel caster with total lock, trailing end of caster, housing made of pressed steel, bright zinc plated, blue passivated, double ball bearing swivel head, wheel axle with nut, plate fitting. Wheel center made of Polyamide, Tread: Polyurethane, precision ball bearing, with threadguards



BETTER MOBILITY. BETTER LIFE.



Picture may differ from original product

Technical Data

Wheel diameter	125 mm
Wheel width	32 mm
Caster width	60 mm
Plate size	77 x 67 mm
Plate hole centers	61,5/56 x 51,5/46,5 mm
Plate hole	8,5 mm
Dome-Ø	60 mm
Offset	41 mm
Swivel Interference	262 mm
Overall height	160 mm
Temperature	- 25 / - 25 °C
Standard	EN 12530
Weight	1.031 kg
Swivel Radius	131 mm
Hardness of tread	Shore D 42
Load capacity (dynamic)	100 kg
Load capacity (static)	200 kg

Dimensions

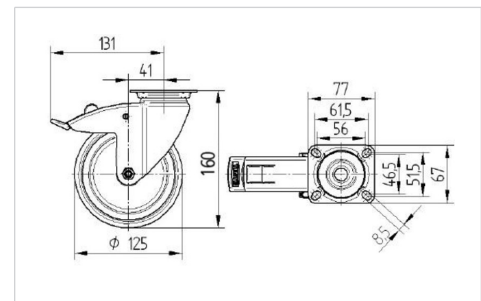

Structure & Mounting

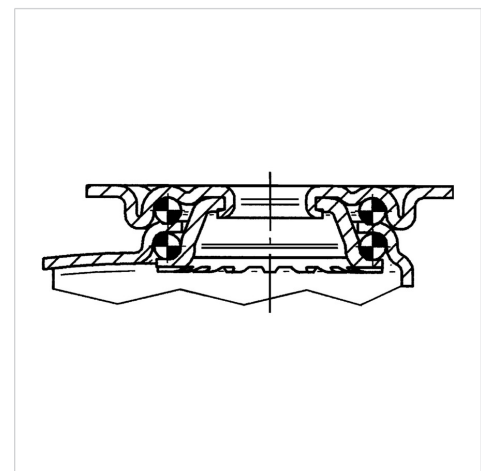

Advantages at a glance

Roll performance	● ● ● ○ ○
Movement noise	● ● ● ○ ○
Attrition	● ● ● ● ○
Corrosion resistance	● ● ● ○ ○

AGILA

2477UAP125P50

EAN 4031582302271



BETTER MOBILITY. BETTER LIFE.

Structure & Mounting

