

AGILA

2478DIK075P60

EAN 4031582030082

Fixed castor, Fork made of pressed steel, bright zinc plated, blue passivated, plate fitting.
Wheel centre made of pressed steel, Tread: solid rubber, grey non-marking, with threadguards, cone ball bearing



BETTER MOBILITY. BETTER LIFE.



Picture may differ from original product

Technical Data

Wheel diameter	75 mm
Wheel width	25 mm
Castor width	43 mm
Size of Plate	67 x 60 mm
Plate hole centres	48/40 x 48/40 mm
Plate hole	6,3 mm
Dome-Ø	43 mm
Overall height	100 mm
Temperature	- 20 / + 60 °C
Standard	EN 12530
Weight	0.312 kg
Hardness of tread	Shore A 80
Load capacity	55 kg
Load capacity (static)	110 kg

Dimensions

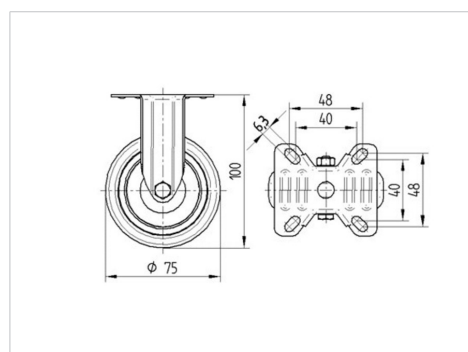

Advantages at a glance

Roll performance	● ● ● ○ ○
Movement noise	● ● ● ○ ○
Attrition	● ● ● ○ ○
Corrosion resistance	● ● ● ○ ○

AGILA

2478DIK075P60

EAN 4031582030082



BETTER MOBILITY. BETTER LIFE.

Structure & Mounting

