

# AGILA

2478DIK100P50

EAN 4031582030228

Fixed caster, Fork made of pressed steel, bright zinc plated, blue passivated, wheel axle with nut, plate fitting.

Longside of plate 90° off track.

Wheel center made of pressed steel, Tread: solid rubber, grey non-marking, with threadguards, cone ball bearing



BETTER MOBILITY. BETTER LIFE.



Picture may differ from original product

## Technical Data

Wheel diameter	100 mm
Wheel width	32 mm
Caster width	60 mm
Plate size	77 x 67 mm
Plate hole centers	61,5/56 x 51,5/46,5 mm
Plate hole	8,5 mm
Dome-Ø	60 mm
Overall height	135 mm
Temperature	- 20 / + 85 °C
Standard	EN 12530
Weight	0.781 kg
Hardness of tread	Shore A 80
Load capacity (dynamic)	80 kg
Load capacity (static)	160 kg

## Dimensions

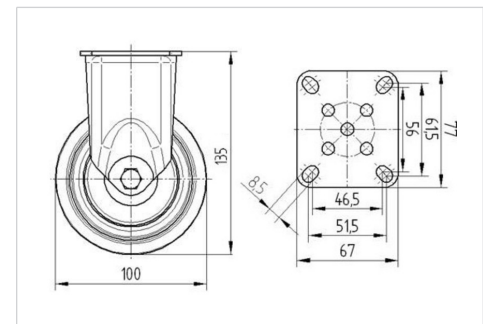

## Advantages at a glance

Roll performance	● ● ● ○ ○
Movement noise	● ● ● ○ ○
Attrition	● ● ● ○ ○
Corrosion resistance	● ● ● ○ ○

# AGILA

2478DIK100P50

EAN 4031582030228



BETTER MOBILITY. BETTER LIFE.

## Structure & Mounting

