

AGILA

2478PJO100P50

EAN 4031582030303

Fixed castor, Fork made of pressed steel, bright zinc plated, blue passivated, wheel axle with nut, plate fitting.

Longside of plate 90° off track.

Wheel centre made of Polypropylene, Tread: TENTEprene (thermoplastic rubber), grey non-marking, plain bearing



BETTER MOBILITY. BETTER LIFE.



Picture may differ from original product

Technical Data

Wheel diameter	100 mm
Wheel width	32 mm
Castor width	60 mm
Size of Plate	77 x 67 mm
Plate hole centres	61,5/56 x 51,5/46,5 mm
Plate hole	8,5 mm
Dome-Ø	60 mm
Overall height	135 mm
Temperature	- 20 / + 60 °C
Standard	EN 12530
Weight	0.477 kg
Hardness of tread	Shore A 87
Load capacity	80 kg
Load capacity (static)	160 kg

Dimensions

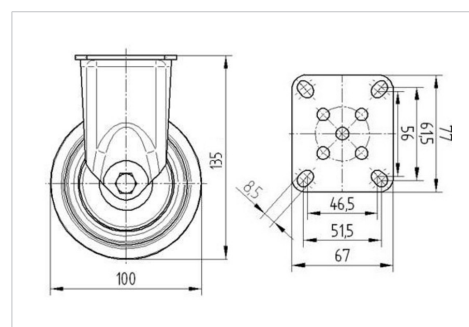

Advantages at a glance

Roll performance	● ● ● ○ ○
Movement noise	● ● ● ○ ○
Attrition	● ● ● ○ ○
Corrosion resistance	● ● ● ○ ○

AGILA

2478PJO100P50

EAN 4031582030303



BETTER MOBILITY. BETTER LIFE.

Structure & Mounting

