

AGILA

2478PJP100P50

EAN 4031582030365

Fixed caster, Fork made of pressed steel, bright zinc plated, blue passivated, wheel axle with nut, plate fitting.

Longside of plate 90° off track.

Wheel center made of Polypropylene, Tread: TENTEprene (thermoplastic rubber), grey non-marking, precision ball bearing, with threadguards



BETTER MOBILITY. BETTER LIFE.



Picture may differ from original product

Technical Data

Wheel diameter	100 mm
Wheel width	32 mm
Caster width	60 mm
Plate size	77 x 67 mm
Plate hole centers	61,5/56 x 51,5/46,5 mm
Plate hole	8,5 mm
Dome-Ø	60 mm
Overall height	135 mm
Temperature	- 20 / + 60 °C
Standard	EN 12530
Weight	0.53 kg
Hardness of tread	Shore A 87
Load capacity (dynamic)	100 kg
Load capacity (static)	200 kg

Dimensions

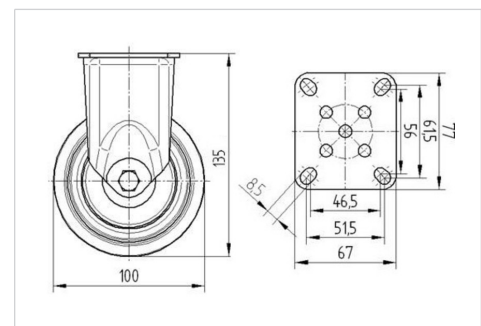

Advantages at a glance

Roll performance	● ● ● ○ ○
Movement noise	● ● ● ○ ○
Attrition	● ● ● ○ ○
Corrosion resistance	● ● ● ○ ○

AGILA

2478PJP100P50

EAN 4031582030365



BETTER MOBILITY. BETTER LIFE.

Structure & Mounting

