

INTEGRAL TWIN

2940UAP150R05-28

EAN 4031582302509

Swivel castor, frame made of pressed steel, precision ball bearing in swivel head, housing with synthetic cover, solid plug fitting. Wheel centre made of Polyamide, Tread: Polyurethane, precision ball bearing
Hint: TÜV Süd certified product.



BETTER MOBILITY. BETTER LIFE.



Picture may differ from original product

Technical Data

Wheel diameter	150 mm
Wheel width	15 mm
Castor width	75 mm
Bolt-Ø	28 mm
Bolt length	45 mm
Dome-Ø	70 mm
Offset	45 mm
Swivel Interference	248 mm
Overall height	175 mm
Temperature	- 25 / - 25 °C
Standard	EN 12531
Weight	1.003 kg
Swivel Radius	124 mm
Hardness of tread	Shore D 42
Load capacity	150 kg
Load capacity (static)	450 kg

Advantages at a glance

Roll performance	● ● ● ● ●
Movement noise	● ● ● ○ ○
Attrition	● ● ● ● ○
Corrosion resistance	● ● ● ○ ○

Dimensions

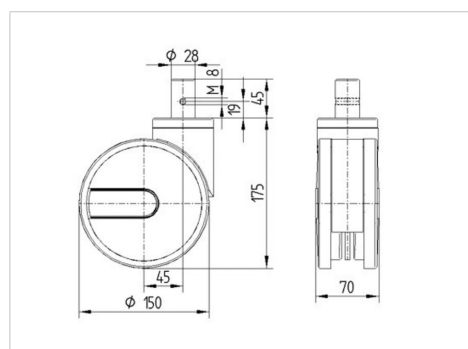

Structure & Mounting

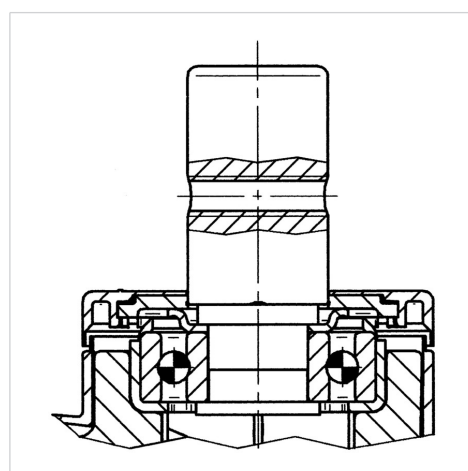

INTEGRAL TWIN

2940UAP150R05-28

EAN 4031582302509



BETTER MOBILITY. BETTER LIFE.

Structure & Mounting

