

INTEGRAL TWIN

2940UAP150R05-28

EAN 4031582302509

회전 캐스터, 압착된 강철로 만든 프레임, 회전 헤드의 정밀 볼 베어링, 합성 커버를 사용한 하우징, 솔리드 플러그 피팅. 폴리아미드로 만든 휠 중심, 트레드: 폴리우레탄, 정밀 볼 베어링
 힌트: TÜV Süd certified product.



BETTER MOBILITY. BETTER LIFE.



Picture may differ from original product

기술 데이터

휠 직경	150 mm
휠 폭	15 mm
캐스터 너비	75 mm
볼트-Ø	28 mm
볼트 길이	45 mm
덤-Ø	70 mm
오프셋	45 mm
회전간섭	248 mm
총 높이	175 mm
온도	- 25 / - 25 °C
표준	EN 12531
무게	1.003 kg
회전 반경	124 mm
트레드 경도	Shore D 42
동하중	150 kg
정지하중	450 kg

Advantages at a glance

롤 저항성	● ● ● ● ●
이동 소음	● ● ● ○ ○
마찰	● ● ● ● ○
부식 방지	● ● ● ○ ○

Dimensions

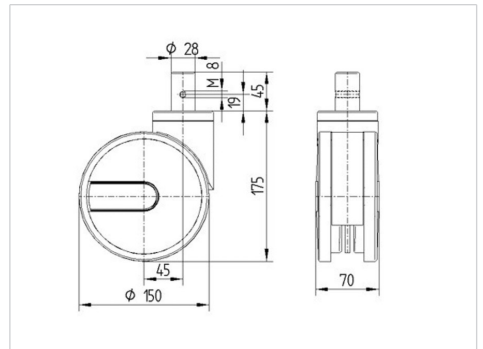

Structure & Mounting

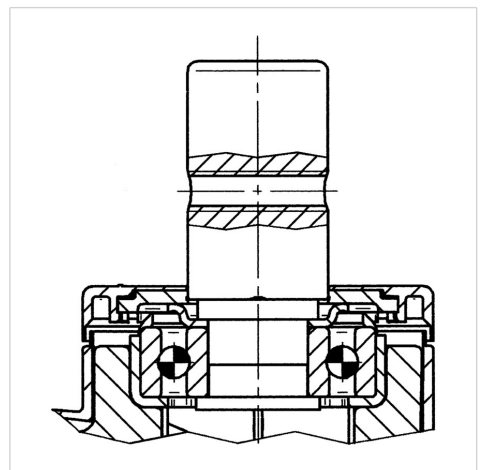

INTEGRAL TWIN

2940UAP150R05-28

EAN 4031582302509



BETTER MOBILITY. BETTER LIFE.

Structure & Mounting

