

# INTEGRAL TWIN

2944UAP100R26-28S45 4xM8

EAN 4031582302523

Swivel castor with central, total lock and central directional lock, frame made of pressed steel, precision ball bearing in swivel head, housing with synthetic cover, stem with cam hole for profile bars. Wheel centre made of Polyamide, Tread: Polyurethane, precision ball bearing  
Hint: TÜV Süd certified product.



BETTER MOBILITY. BETTER LIFE.



Picture may differ from original product

## Technical Data

Wheel diameter	100 mm
Wheel width	15 mm
Castor width	63 mm
Bolt-Ø	28 mm
Bolt length	96 mm
Dome-Ø	61.5 mm
Offset	31 mm
Swivel Interference	170 mm
Overall height	129 mm
Temperature	- 25 / - 25 °C
Standard	EN 12531
Weight	1.042 kg
Swivel Radius	85 mm
Hardness of tread	Shore D 42
Load capacity	125 kg
Load capacity (static)	375 kg

## Dimensions

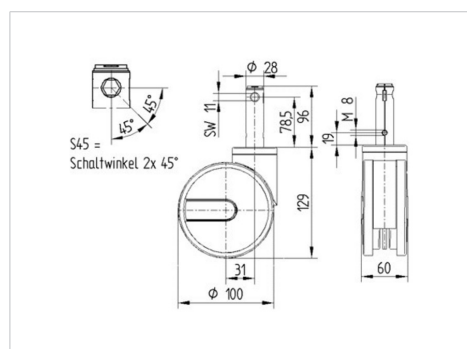

## Advantages at a glance

Roll performance	● ● ● ● ●
Movement noise	● ● ● ○ ○
Attrition	● ● ● ● ○
Corrosion resistance	● ● ● ○ ○

# INTEGRAL TWIN

2944UAP100R26-28S45 4xM8

EAN 4031582302523



BETTER MOBILITY. BETTER LIFE.

## Structure & Mounting

---

