

INTEGRAL TWIN

2944UAP100R36-32S30 4xM6

EAN 4031582302530

Swivel castor with central, total lock and central directional lock, frame made of pressed steel, precision ball bearing in swivel head, housing with synthetic cover, stem with cam hole for profile bars, short version. Wheel centre made of Polyamide, Tread: Polyurethane, precision ball bearing
Hint: TÜV Süd certified product.



BETTER MOBILITY. BETTER LIFE.



Picture may differ from original product

Technical Data

Wheel diameter	100 mm
Wheel width	15 mm
Castor width	63 mm
Bolt-Ø	32 mm
Bolt length	51 mm
Dome-Ø	61.5 mm
Offset	31 mm
Swivel Interference	170 mm
Overall height	129 mm
Temperature	- 25 / - 25 °C
Standard	EN 12531
Weight	1.04 kg
Swivel Radius	85 mm
Hardness of tread	Shore D 42
Load capacity	125 kg
Load capacity (static)	375 kg

Dimensions

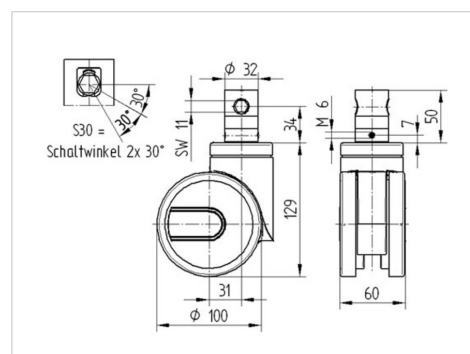

Advantages at a glance

Roll performance	● ● ● ● ●
Movement noise	● ● ● ○ ○
Attrition	● ● ● ● ○
Corrosion resistance	● ● ● ○ ○

INTEGRAL TWIN

2944UAP100R36-32S30 4xM6

EAN 4031582302530



BETTER MOBILITY. BETTER LIFE.

Structure & Mounting

