

INTEGRAL TWIN

2946UAP150R36-32S30 4xM6

EAN 4031582302639

Swivel caster with central lock, Frame made of pressed steel, precision ball bearing in swivel head, housing with synthetic cover, stem with cam hole for profile bars, short version. Wheel center made of Polyamide, Tread: Polyurethane, precision ball bearing
Hint: TÜV Süd certified product.



BETTER MOBILITY. BETTER LIFE.



Picture may differ from original product

Technical Data

Wheel diameter	150 mm
Wheel width	15 mm
Caster width	75 mm
Bolt-Ø	32 mm
Bolt length	51 mm
Dome-Ø	70 mm
Offset	45 mm
Swivel Interference	248 mm
Overall height	175 mm
Temperature	- 25 / - 25 °C
Standard	EN 12531
Weight	1.421 kg
Swivel Radius	124 mm
Hardness of tread	Shore D 42
Load capacity (dynamic)	150 kg
Load capacity (static)	450 kg

Dimensions

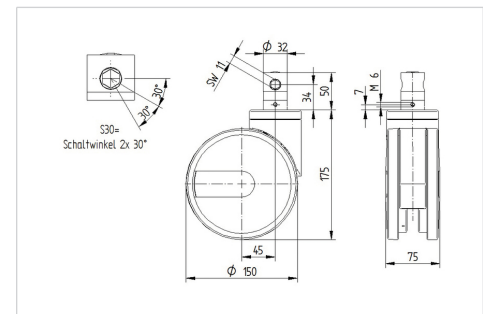

Advantages at a glance

Roll performance	● ● ● ● ●
Movement noise	● ● ● ○ ○
Attrition	● ● ● ○ ○
Corrosion resistance	● ● ● ○ ○

INTEGRAL TWIN

2946UAP150R36-32S30 4xM6

EAN 4031582302639



BETTER MOBILITY. BETTER LIFE.

Structure & Mounting

