

AGILA TWIN

2970DIK050P40

EAN 4031582302653

Swivel castor, housing made of pressed steel, bright zinc plated, blue passivated, double ball bearing swivel head, wheel axle with nut, plate fitting. Wheel centre made of pressed steel, Tread: solid rubber, grey non-marking, with threadguards, cone ball bearing



BETTER MOBILITY. BETTER LIFE.



Picture may differ from original product

Technical Data

Wheel diameter	50 mm
Wheel width	19 mm
Castor width	53 mm
Size of Plate	60 x 60 mm
Plate hole centres	48/38 x 48/38 mm
Plate hole	6,3 mm
Dome-Ø	53 mm
Offset	25 mm
Swivel Interference	106 mm
Overall height	69 mm
Temperature	- 20 / + 85 °C
Standard	EN 12530
Weight	0.344 kg
Swivel Radius	53 mm
Hardness of tread	Shore A 80
Load capacity	60 kg
Load capacity (static)	120 kg

Advantages at a glance

Roll performance	● ● ● ○ ○
Movement noise	● ● ● ○ ○
Attrition	● ● ● ○ ○
Corrosion resistance	● ● ● ○ ○

Dimensions

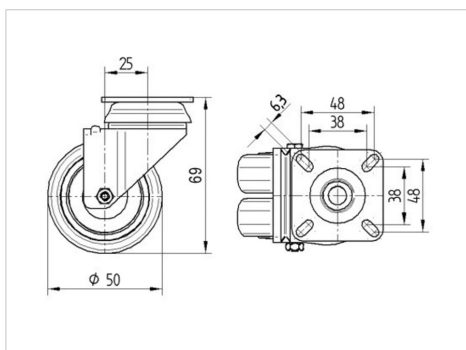

Structure & Mounting

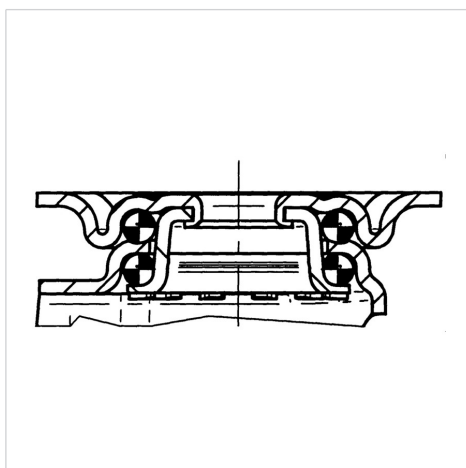

AGILA TWIN

2970DIK050P40

EAN 4031582302653



BETTER MOBILITY. BETTER LIFE.

Structure & Mounting

