

AGILA TWIN

2970DIK075P30-10

EAN 4031582302660

Swivel caster, housing made of pressed steel, bright zinc plated, blue passivated, double ball bearing swivel head, wheel axle with nut, bolt hole. Wheel center made of pressed steel, Tread: solid rubber, grey non-marking, with threadguards, cone ball bearing



BETTER MOBILITY. BETTER LIFE.



Picture may differ from original product

Technical Data

Wheel diameter	75 mm
Wheel width	25 mm
Caster width	71 mm
Center hole	10,3 mm
Dome-Ø	65 mm
Offset	31.4 mm
Swivel Interference	145 mm
Overall height	99 mm
Temperature	- 20 / + 85 °C
Standard	EN 12530
Weight	0.755 kg
Swivel Radius	72.5 mm
Hardness of tread	Shore A 80
Load capacity (dynamic)	100 kg
Load capacity (static)	200 kg

Advantages at a glance

Roll performance	● ● ● ○ ○
Movement noise	● ● ● ○ ○
Attrition	● ● ● ○ ○
Corrosion resistance	● ● ● ○ ○

Dimensions

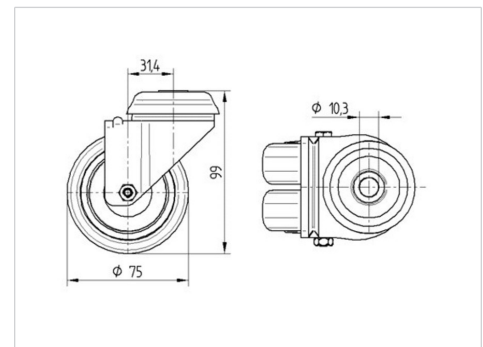

Structure & Mounting

